

While summertime is a time for relaxation and less structure, it is also a time to refresh, review, and enrich. Studies show that an hour a week is all that it takes to strengthen math skills and say goodbye to the summer learning loss.

The summer work file contains several review concepts and skills that are essential for success in both grade level and advanced math classes next year. You will need to download this file and print it. You will need to clearly answer the questions and show the work associated with your answers. Work should be easily identifiable with the problem it is for and readable!

This packet is broken into two sections: Part 1 and Part 2. Part 1 must be completed by all students regardless of their math placement. Part 2 must be completed by all advanced math students, and anyone desiring to have the opportunity to join the advanced math class.

Calculators should not be used unless working with percent concepts.

These packets will be collected by the math teachers on Friday, August 25, 2023.

Mathematical foundational skills are essential life skills no matter what math class you are in. We recommend that you also start (and keep) a math journal whenever you use problems solving skills or logical skills as you are using math. You'd be surprised at all the places you use math without realizing you are using math!

St. Bonaventure Math Teachers

MATH

REVIEW PACKET

FOR

7TH into 8TH GRADE

While summertime is a time for relaxation and less structure it is also a time to refresh, review, and enrich. This file contains several review concepts and skills that are essential for success in both grade level and advanced math classes next year. You will need to print this file.

This packet is broken into two sections: Part 1 and Part 2. Part 1 must be completed by all students regardless of their math placement. Part 2 must be completed by all advanced math students, and anyone desiring to have the opportunity to join the advanced math class.

Calculators should not be used unless working with percent concepts. All work should be shown and easy to read, with answers clearly identified.

These packets will be collected by the math teachers at the end of the first week of school.

Studies show that an hour a week is all that it takes to strengthen math skills and say goodbye to summer learning loss. Mathematical foundational skills are essential no matter what math class you are in.

Summer Math Packet

Part 1

Find the sum or difference.

1. $-80 + 77$

2. $77 + 160$

3. $-64 + (-33)$

4. $104 - (-92)$

5. $-105 - (-122)$

6. $185 - (-154)$

7. $-53 - (-59)$

8. $-6 + (-35)$

9. $15 - (-26) - (-39)$

10. $-93 + 191 + (-179)$

11. $18 + (-34) + 52$

12. $-50 - (-93) + (-17)$

Find the product or quotient.

13. $60 \div 12$

14. $-194 \div (-2)$

15. $88 \cdot (-2)$

16. $-12 \cdot 10$

17. $-10 \cdot (-10)$

18. $90 \div (-6)$

19. $3 \cdot (-59)$

20. $-7 \cdot (-2)$

21. $-28 \cdot (-22) \div (-88)$

22. $-56 \cdot 140 \div (-80)$

23. $108 \div (-12) \cdot (-12)$

24. $-84 \cdot (-17) \div 42$

Evaluate the numerical expression. (Be sure to use the order of operations!)

25. $-78 + (-2) \cdot (-56)$

26. $-65 + 6 \div (-3) + 40$

27. $-94 - (84 - 10)$

28. $43 + (-23) - (-57)$

29. $-15 - (-10) + 5 \cdot (-4)$

30. $-26 - (-64) + (-93)$

31. $-84 \div 4 + (-20)$

32. $-56 + (-50) + (-10) \cdot (-9)$

Find the sum, difference, product, or quotient.

33. $38.61 + 36.841$

34. $1.755 - 1.23$

35. $0.71 \cdot 9.2$

36. $13.12 \div 0.1$

37. $3.651 - (-12.63)$

38. $-3.9 + (-7.6)$

39. $17.6 \cdot 4.3$

40. $6 \cdot (-16.7)$

41. $26.474 - 14.527$

42. $-2.1 + 3.78$

43. $-6.15 \div (-8.2)$

44. $-12.8 \cdot (-4.88)$

Find the sum, difference, product, or quotient.

45. $15 \frac{1}{2} + 15 \frac{1}{4}$

46. $18 \frac{11}{20} - 17 \frac{1}{2}$

47. $2 \frac{1}{4} \cdot 1 \frac{4}{5}$

48. $3 \frac{1}{2} \div 1 \frac{3}{7}$

49. $3 \frac{1}{3} - 5 \frac{1}{9}$

50. $5 \cdot (-1 \frac{2}{5})$

51. $-4 \frac{2}{3} + (-1 \frac{3}{4})$

52. $-\frac{5}{6} \div (-2 \frac{1}{6})$

53. $9 \div (-4 \frac{1}{2})$

54. $-18 + 3 \frac{4}{5}$

55. $-5 \frac{2}{3} \cdot (-2 \frac{5}{6})$

56. $-5 \frac{3}{4} - (-3 \frac{7}{8})$

Solving Equations

Solving One-Step Equations

- Cancel out the number on the same side of the equation as the variable by using the inverse operation. (Addition/Subtraction; Multiplication/Division). Be sure to do the same thing to both sides of the equation!

$$\text{ex: } 6x = -18 \rightarrow \frac{\cancel{6}x = -18}{\cancel{6} \quad 6} \rightarrow \text{answer: } (x = -3)$$

$$\text{ex: } y + 23 = -9 \rightarrow y + \cancel{23} = -9 \rightarrow \text{answer: } (y = -32)$$

$\quad \quad \quad -23 \quad -23$

$$\text{ex: } \frac{h}{3} = 4 \rightarrow \cancel{3} \cdot \frac{h}{\cancel{3}} = 4 \cdot 3 \rightarrow \text{answer: } (h = 12)$$

$$\text{ex: } w - 13 = -5 \rightarrow w - \cancel{13} = -5 \rightarrow \text{answer: } (w = 8)$$

$\quad \quad \quad +13 \quad +13$

Solving Two-Step Equations

- Undo operations using inverse operations one at a time using the order of operations in reverse. (i.e.: undo addition/subtraction before undoing multiplication/division)

$$\text{ex: } 7x - 4 = -32 \rightarrow 7x - \cancel{4} = -32 \rightarrow \frac{\cancel{7}x = -28}{\cancel{7} \quad 7} \rightarrow \text{answer: } (x = -4)$$

$\quad \quad \quad +4 \quad +4$

$$\text{ex: } \frac{j}{5} + 13 = 15 \rightarrow \frac{j}{5} + \cancel{13} = 15 \rightarrow \cancel{5} \cdot \frac{j}{\cancel{5}} = 2 \cdot 5 \rightarrow \text{answer: } (j = 10)$$

$\quad \quad \quad -13 \quad -13$

$$\text{ex: } \frac{b+7}{3} = -2 \rightarrow \cancel{3} \cdot \frac{b+7}{\cancel{3}} = -2 \cdot 3 \rightarrow b + \cancel{7} = -6 \rightarrow \text{answer: } (b = -13)$$

$\quad \quad \quad -7 \quad -7$

Solve the one-step equation.

57. $19 + j = -34$

58. $m - 26 = 13$

59. $\frac{x}{5} = -3$

60. $12f = 216$

61. $g - (-3) = -7$

62. $\frac{h}{9} = 13$

63. $b + (-3) = -9$

64. $-4w = -280$

Solve the two-step equation.

65. $5m - 3 = 27$

66. $7 + \frac{y}{2} = -3$

67. $4 + 3r = -8$

68. $\frac{1}{2}p - 4 = 7$

69. $\frac{k+8}{3} = -2$

70. $\frac{f}{5} - (-13) = 12$

71. $-15 - \frac{g}{3} = -5$

72. $-8 + 4m = 2$

73. $-18 - \frac{3}{4}v = 3$

74. $\frac{-5+n}{4} = -1$

75. $3.5m + 0.75 = -6.25$

76. $2y + 3 = 19$

Proportions and Percent

Solving Proportions

- Set cross-products equal to each other and then solve the one-step equation for the given variable.

ex: $\frac{5}{6} = \frac{4}{10} \rightarrow 5 \cdot 10 = 4b \rightarrow \frac{50}{4} = \frac{4b}{4} \rightarrow$ answer: $b = 12.5$

Solving Percent Problems with Proportions

- Set up and solve a proportion as follows: $\frac{\%}{100} = \frac{\text{part}}{\text{whole}}$

ex: 25 is what percent of 500? $\rightarrow \frac{x}{100} = \frac{25}{500} \rightarrow$ answer: $x = 5\%$

ex: What is 15% of 88? $\rightarrow \frac{15}{100} = \frac{x}{88} \rightarrow$ answer: $x = 13.2$

ex: 18 is 30% of what number? $\rightarrow \frac{30}{100} = \frac{18}{x} \rightarrow$ answer: $x = 60$

Solving Percent Problems with Equations

- Translate the question to an equation and then solve. (Be sure to convert percents to decimals or fractions.)

ex: 20 is 40% of what number? $\rightarrow 20 = 0.4x \rightarrow$ answer: $x = 50$

ex: 8 is what percent of 32? $\rightarrow 8 = 32x \rightarrow x = 0.25 \rightarrow$ answer: 25%

ex: What is 25% of 88? $\rightarrow x = 0.25 \cdot 88 \rightarrow$ answer: $x = 22$

Real-World Percent Problems

(This is just one way of many to solve real-world percent problems)

- Tax: Find the amount of tax using a proportion or equation. Then add the tax to the original amount to find the total cost.
- Discount: Find the amount of the discount using a proportion or equation. Then subtract the amount of discount from the original price to find the sale price.

Solve the proportion.

77. $\frac{h}{6} = \frac{20}{24}$

78. $\frac{5}{7} = \frac{c}{14}$

79. $\frac{6}{8} = \frac{21}{b}$

80. $\frac{30}{j} = \frac{26}{39}$

81. $\frac{5}{k} = \frac{15}{20}$

82. $\frac{32}{112} = \frac{a}{14}$

83. $\frac{16}{7} = \frac{18}{9}$

84. $\frac{w}{60} = \frac{15}{200}$

Solve the percent problem.

85. Find 15% of 85.

86. 6 is 75% of what number?

87. 40 is what percent of 320?

88. What is 20% of 45?

89. 70 is what percent of 350?

90. Find 33. $\bar{3}$ % of 81.

91. A \$58 camera is on sale for 20% off. Find the sale price.

92. Find the total price of a \$14.00 shirt including the 7% sales tax.

REVIEW: Rates

Name _____

Key Concept and Vocabulary

You pay \$12 for 4 hot dogs.



$$\text{Rate} = \frac{\$12}{4 \text{ hot dogs}}$$

$$\text{Unit Rate} = \frac{\$3}{1 \text{ hot dog}}$$



Visual Model

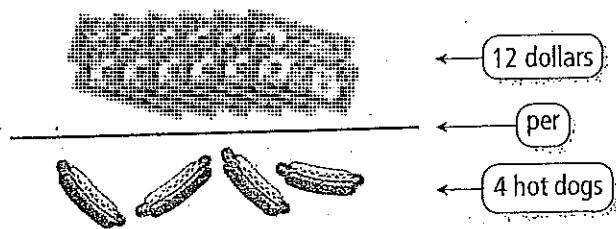

Skill Examples

- You drive 100 miles in 2 hours.
Your unit rate is 50 miles per hour.
- You earn \$40 in 5 hours.
Your unit rate is \$8 per hour.
- You save \$240 in 6 months.
Your unit rate is \$40 per month.

Application Example

- Janice was 44 inches tall when she was 8 years old. She was 52 inches tall when she was 12 years old. What was her unit rate?

She grew 8 inches in 4 years: $\frac{8}{4} = \frac{2}{1}$.

∴ Her unit rate is 2 inches per year.



PRACTICE MAKES PURR-FECT™

Check your answers at BigIdeasMath.com.

Write the unit rate in words and as a fraction for each situation.

- You fly 2000 miles in 4 hours.

Words

Fraction

- You pay 15 dollars for 3 pizzas.

Words

Fraction

- You pay \$4 sales tax on a \$50 purchase.

Words

Fraction

- You earn \$25 for mowing 5 lawns.

Words

Fraction

Circle the name of the person with the greater unit rate.

- Maria saves \$50 in 4 months.
Ralph saves \$60 in 5 months.

- John rides his bicycle 36 miles in 3 hours.
Randy rides his bicycle 30 miles in 2.5 hours.

- Kim earns \$400 for working 40 hours.
Sam earns \$540 for working 45 hours.

- Arlene scores 450 points on 5 tests.
Jolene scores 180 points on 2 tests.

Convert the unit rate.

- $\frac{60 \text{ miles}}{1 \text{ hour}} = \frac{\boxed{} \text{ feet}}{1 \text{ second}}$

- $\frac{2 \text{ gallons}}{1 \text{ hour}} = \frac{\boxed{} \text{ cups}}{1 \text{ minute}}$

REVIEW: Finding the Percent of a Number

Name _____

Key Concept and Vocabulary

40% of 60 is 24.

$$0.4 \times 60 = 24$$

$$\frac{2}{5} \times 60 = 24$$

Write percent as decimal or fraction and multiply.

Finding a part.



Visual Model

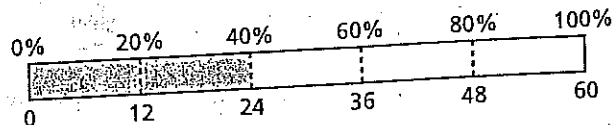

Skill Examples

- 30% of 50: $0.3 \times 50 = 15$
- 45% of 80: $0.45 \times 80 = 36$
- 110% of 40: $1.1 \times 40 = 44$
- 25% of 240: $0.25 \times 240 = 60$

Application Example

5. 28% of the 200 people who answered a survey own a dog. How many of the 200 people in the survey own a dog?

$$0.28 \times 200 = 56$$

∴ 56 of the 200 people own a dog.

PRACTICE MAKES PURR-FECT™



Check your answers at BigIdeasMath.com.

Find the percent of the number.

- 25% of 40 = _____
- 20% of 35 = _____
- 65% of 110 = _____
- 125% of 20 = _____
- $33\frac{1}{3}\%$ of 60 = _____
- 95% of 400 = _____
- 200% of 31 = _____
- 18% of 90 = _____
- 1% of 800 = _____
- 60% of 60 = _____
- 100% of 59 = _____
- 1000% of 59 = _____

Write the question represented by the model. Then answer the question.

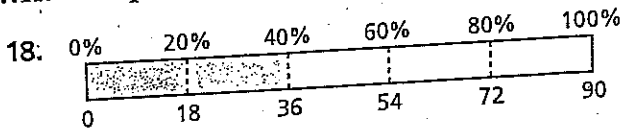

Question: _____
Answer: _____

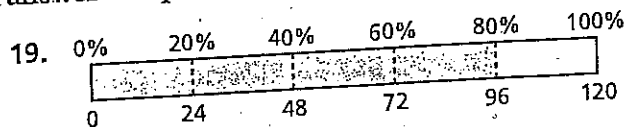

Question: _____
Answer: _____

20. **ENDANGERED SPECIES** Sixty percent of a species of butterfly died due to loss of habitat. Originally, there were 10,000 butterflies. How many are left? _____

21. **SALES TAX** You buy 4 breakfast sandwiches at \$2.59 each, 4 hashbrowns at \$1.10 each, and 4 bottles of orange juice at \$1.25 each. The sales tax is 6%. Find the total cost of the 4 meals, including sales tax. _____

REVIEW: Finding the Percent of a Number

Name _____

Key Concept and Vocabulary

40% of 60 is 24.

$$0.4 \times 60 = 24$$

$$\frac{2}{5} \times 60 = 24$$

Write percent as decimal or fraction and multiply.

Finding a part.



Visual Model

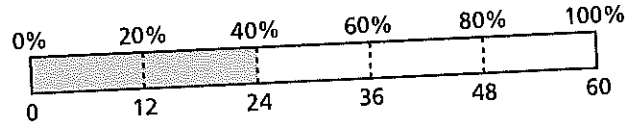

Skill Examples

- 30% of 50: $0.3 \times 50 = 15$
- 45% of 80: $0.45 \times 80 = 36$
- 110% of 40: $1.1 \times 40 = 44$
- 25% of 240: $0.25 \times 240 = 60$

Application Example

- 28% of the 200 people who answered a survey own a dog. How many of the 200 people in the survey own a dog?

$$0.28 \times 200 = 56$$

∴ 56 of the 200 people own a dog.

PRACTICE MAKES PURR-FECT™



Check your answers at BigIdeasMath.com.

Find the percent of the number.

- 25% of 40 = _____
- 20% of 35 = _____
- 65% of 110 = _____
- 125% of 20 = _____
- $33\frac{1}{3}\%$ of 60 = _____
- 95% of 400 = _____
- 200% of 31 = _____
- 18% of 90 = _____
- 1% of 800 = _____
- 60% of 60 = _____
- 100% of 59 = _____
- 1000% of 59 = _____

Write the question represented by the model. Then answer the question.

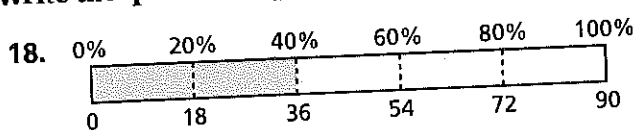

Question: _____

Answer: _____

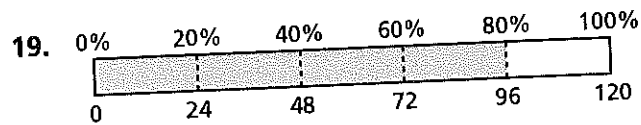

Question: _____

Answer: _____

- ENDANGERED SPECIES** Sixty percent of a species of butterfly died due to loss of habitat. Originally, there were 10,000 butterflies. How many are left? _____

- SALES TAX** You buy 4 breakfast sandwiches at \$2.59 each, 4 hashbrowns at \$1.10 each, and 4 bottles of orange juice at \$1.25 each. The sales tax is 6%. Find the total cost of the 4 meals, including sales tax. _____

REVIEW: Estimating and Finding a Discount

Name _____

Key Concept and Vocabulary

A discount is a decrease in the original price of an item. To find the discount, write the percent as a decimal or fraction and multiply it by the original price of the item.



Visual Model

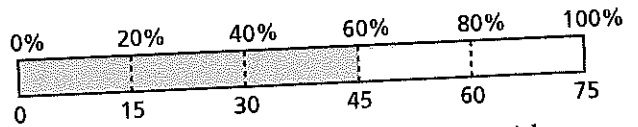

The sale price of a \$75 necklace with a 60% discount is $75 - 45 = 30$.

Application Examples

1. The original price of a book is \$18.79.
The discount is 20%.

Estimate: Round 18.79 to 20.

$$0.2 \times 20 = 4$$

- ∴ The estimate for the discount is \$4.

Actual: $0.2 \times 18.79 \approx 3.76$

- ∴ The actual discount is \$3.76.
The sale price of the book is
 $18.79 - 3.76 = 15.03$.

2. The original price of a pair of in-line skates is \$209.99. The discount is 15%.

Estimate: Round 209.99 to 200.

$$0.15 \times 200 = 30$$

- ∴ The estimate for the discount is \$30.

Actual: $0.15 \times 209.99 \approx 31.50$

- ∴ The actual discount is \$31.50. The sale price of the pair of in-line skates is $209.99 - 31.50 = 178.49$.

PRACTICE MAKES PURR-FECT™



Check your answers at BigIdeasMath.com.

Estimate the discount. Then find the actual discount and the sale price.

3. **TRUMPET** The original price of a trumpet is \$319.29. The discount is 25%.

4. **SHOES** The original price of a pair of shoes is \$47.99. The discount is 40%.

5. **LAMP** The original price of a lamp is \$17.09. The discount is 15%.

6. **RING** The original price of a ring is \$96.75. The discount is 60%.

7. **ELECTRONICS** The original price of a home theater system is \$243.89. The discount is 75%.

8. **BASEBALL** The original price of a baseball glove is \$26.99. The discount is 30%.

9. **SEWING MACHINE** The original price of a sewing machine is \$182.96. The discount is 20%.

Geometry

Geometry Basics

- Perimeter is the distance around a polygon
- Circumference is the distance around a circle
- Area is the space inside a figure
- Volume is the capacity of a 3-dimensional figure
- Surface Area is the sum of the areas of all the faces on a 3-dimensional figure

2-Dimensional Geometry Formulas

- Perimeter of Any Figure: sum of side lengths
- Circumference = $\pi \cdot \text{diameter}$
- Area of Parallelogram = base \cdot height
- Area of Triangle = $\frac{1}{2} \cdot \text{base} \cdot \text{height}$
- Area of Trapezoid = $\frac{1}{2} \cdot \text{height}(\text{base}_1 + \text{base}_2)$
- Area of Circle = $\pi \cdot \text{radius}^2$

3-Dimensional Geometry Formulas

- Volume of Rectangular Prism = length \cdot width \cdot height
- Volume of Cylinder = $\pi \cdot \text{radius}^2 \cdot \text{height}$
- Surface Area of Rectangular Prism = $2 \cdot \text{length} \cdot \text{width} + 2 \cdot \text{length} \cdot \text{height} + 2 \cdot \text{height} \cdot \text{width}$
- Surface Area of Cylinder = $2 \cdot \pi \cdot \text{radius}^2 + 2 \cdot \pi \cdot \text{radius} \cdot \text{height}$

Find the perimeter (or circumference) and area. Use 3.14 for pi.

93.

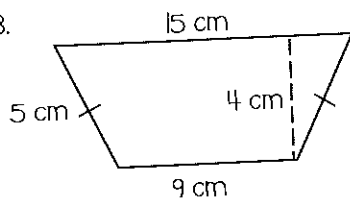

94.

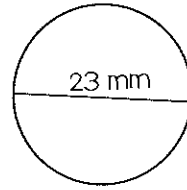

95.

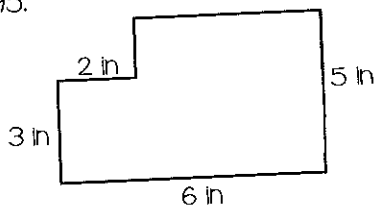

96.

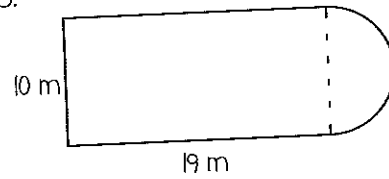

Find the surface area and volume.

97.

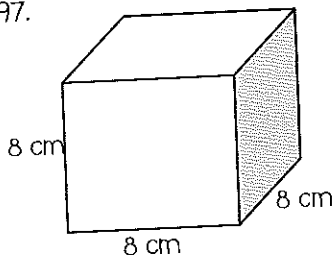

98.

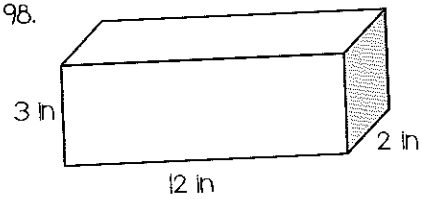

99.

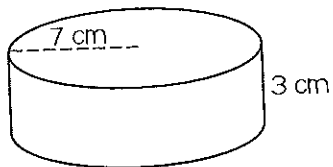

100.

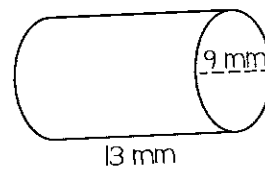

1. Use the frequency distribution to find the average number of movies watched by students during one week. Round your answer to the nearest hundredth.

| Movies Watched in a Week | Tally | Frequency |
|--------------------------|-------|-----------|
| 6 | | 1 |
| 5 | | 0 |
| 4 | | 3 |
| 3 | | 8 |
| 2 | | 6 |
| 1 | | 2 |
| 0 | | 3 |

3. Find the values of a and b .

$m\angle a =$ _____

$m\angle b =$ _____

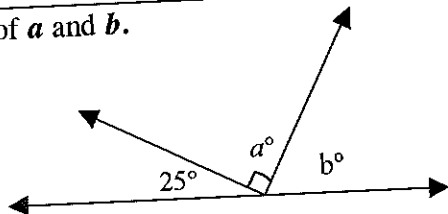

2. Michelle wants to listen to 5 compact discs. Two compact discs are each 51 minutes long and the other three compact discs are each 46 minutes long. How many hours and minutes will it take Michelle to listen to all 5 compact discs?

4. Fill in the missing numbers.

$$\frac{4}{7} = \frac{16}{35} = \frac{\quad}{21} = \frac{140}{\quad} = \frac{\quad}{140}$$

5. Marcela was assigned some math problems for homework. She answered half of them in study hall. After school she completed seven more. If she still has 11 problems to do, how many problems were assigned?

6. Using the pattern in the chart below, how much interest can someone earn on a \$200 deposit in a savings account?

| | | | | | | |
|----------|---------|---------|---------|---------|----------|----------|
| Deposit | \$20.00 | \$40.00 | \$60.00 | \$80.00 | \$100.00 | \$120.00 |
| Interest | \$1.50 | \$3.00 | \$4.50 | \$6.00 | \$7.50 | \$9.00 |

7. What makes the set of integers different from the set of whole numbers?

8. Evaluate:

$$1^{20} + 10^3 =$$

9. If a fly lands on one of the tiles of this floor, what is the probability that it will land on a shaded tile?

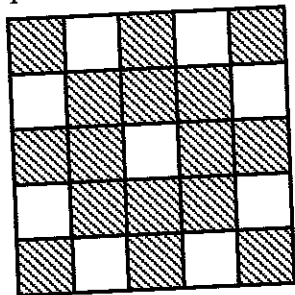

10. Complete the table and graph equation.

$$2x + 3y = 12$$

| x | y |
|----|---|
| -3 | |
| 0 | |
| | 0 |
| 3 | |

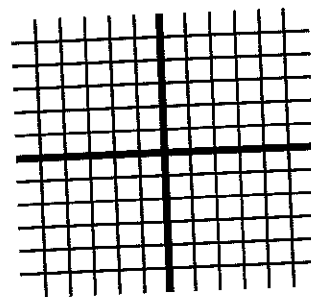

1. Fill in the blanks of the proportion to find 53% of 215. Then solve your proportion.

$$\frac{\quad}{\quad} = \frac{\quad}{\quad}$$

2. Order the given set of numbers from least to greatest:

$$8, \sqrt{41}, 9, \sqrt{56}, \sqrt{65}, 6$$

3. Find the volume of the given rectangular prism.

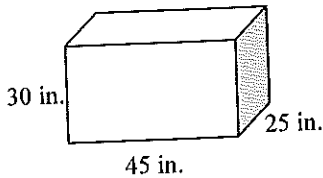

4. The side lengths of a particular triangle are 12, 16, and 20. Is it a right triangle? Justify your response by using the converse of the Pythagorean Theorem.

5. Each of the 12 central angles in the circle is n degrees. Find n .

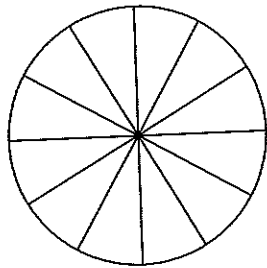

6. Use the following information to create a bar graph.

Several cases of weather-related crop damage were reported in Virginia over the last 10 years. 205 cases were due to excessive heat, 151 were the result of floods, 94 were attributed to lightning, 87 were because of tornadoes, and 31 were due to hurricanes.

7. Find the value of  in the following equation.

$$\triangle \cdot \triangle \cdot \triangle \cdot \triangle = 256$$

8. When Corey added $4821 + 5416 + 4633 + 5221$ on his calculator, he obtained the sum 15,386. Without using a calculator, estimate the sum to see whether his solution is reasonable.

9. Tell whether each given statement is true "always," "sometimes," or "never."

a. a rational number is an integer

b. an irrational number is a real number

c. a rational number is an irrational number

10. Which graph below shows a consistent growth in profits made from video rentals over 6 weeks?

a.)

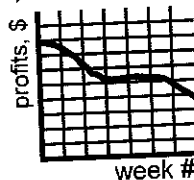

b.)

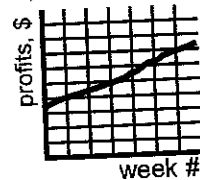

c.)

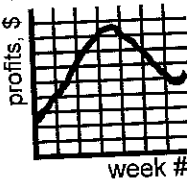

Explain your choice.

1. Solve the equation for K:

$$K + \frac{2}{3} = \frac{8}{9}$$

2. Evaluate

$$5a + 6b - c$$

if $a = 5$, $b = 6$, and $c = 4$.

3. solve

$$\frac{-5+n}{4} = -1$$

4. Triangle CAT is **similar** to triangle DOG.
If $CA = 4$, $AT = 6$, and $DO = 6$, write and solve a proportion to find OG.

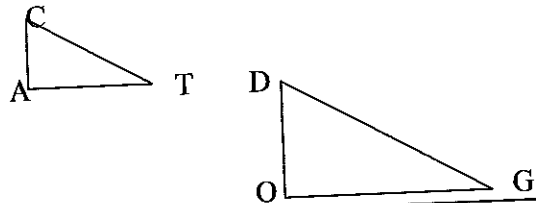

5. Use the area formula for a triangle to compute the area of the triangle shown:

$$A = \frac{1}{2}bh$$

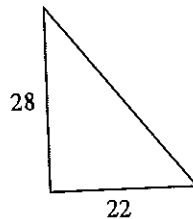

6. Find the mean, median, and mode of the set of numbers: 6, 7, 11, 5, 8, 7, 4, 13, 11, 2.

7. Name the set or sets of numbers to which each of the following real numbers belong (natural, whole, integer, rational, irrational).

a.) 12

b.) $\frac{3}{8}$

c.) $\sqrt{11}$

8. If $n = 7$, evaluate:

$$1 + n^2$$

9. What percent of the boxes have x's in them?

| | | | | | | | |
|---|---|---|---|---|---|---|---|
| x | x | | | x | | x | x |
| | | | x | x | | | |
| | x | x | | | x | x | |
| x | | | | x | x | | |

10. To print T-shirts you need to pay once for the screen to be made and then a small fee for each shirt printed. If you have \$300, how many t-shirts could you have printed? Show how you know.

WE PRINT

screen...\$75
\$2.50/shirt

1. What is the ratio of 5 feet to 5 yards?(It is not 1:1.)

2. The width of a newspaper is $13\frac{3}{4}$ inches. The left margin is $\frac{7}{16}$ inch and the right margin is $\frac{1}{2}$ inch. What is the width of the written page inside the margins?

3. If the measure of an angle is 50° , circle the diagram that could be used to find its **complement**.

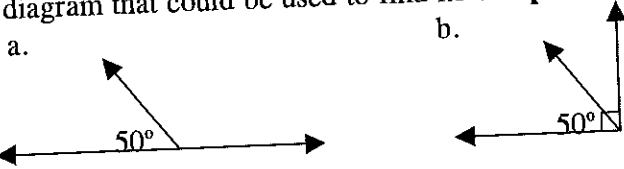

The complement of a 50° angle is _____.

4. 24 oz. of soda cost \$1.29. At that rate, how much would you expect 30 oz. of soda to cost?

5. Shana earned the following scores on quizzes throughout the quarter: $\frac{34}{40}$, $\frac{20}{25}$, $\frac{53}{60}$. Indicate which one of the three was her best score, by converting them to percents.

6. Look for a pattern and complete the table using the pattern.

| M | N |
|-----|-------|
| 1 | 3 |
| 2 | 6 |
| 3 | 9 |
| 4 | _____ |
| : | : |
| 10 | _____ |
| : | : |
| 100 | _____ |

Describe what you have to do to the value of M to get its corresponding N value.

7. Draw a rectangle to show the product of 5 and $(x + 4)$. Then write the product.

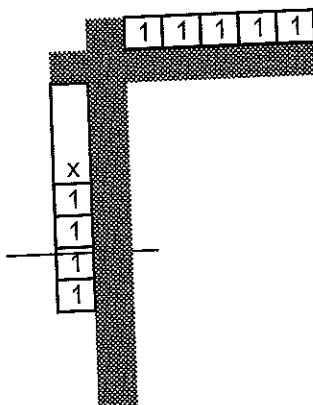

$5(x + 4) =$

8. The chart below shows how Dale has budgeted his money based on a weekly salary from his job after school.

| Purpose | % of total | Amount |
|---------------|------------|---------|
| Food | 25 | \$22.50 |
| Savings | 20 | ? |
| Entertainment | 15 | \$13.50 |
| Clothes | 40 | ? |

- a.) How much does Dale earn each week? _____
 b.) How much of his weekly salary does Dale budget for clothing?

9. Evaluate each expression.

a.) $(3 \times 5)^2$

b.) 3×5^2

10. Compare with $<$ or $>$.

$\sqrt{73}$ _____ $\frac{61}{8}$

1. Make a table of five ordered pairs that solve the given equation. Use these ordered pairs to graph.

$$y = 2x - 3$$

| x | y |
|---|---|
| | |
| | |
| | |
| | |

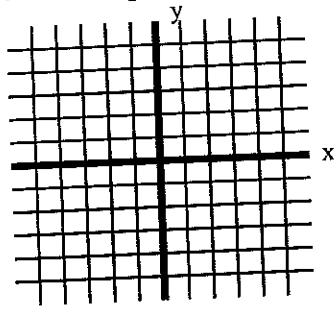

2. Indicate whether each statement is true or false:

- The difference of two whole numbers must be a whole number. _____
- The difference of two integers must be an integer. _____
- The quotient of two integers must be an integer. _____

3. The population of North America is 278,000,000 people, and its area is 7,466,890 square miles. Which is a reasonable estimate for the population density (the number of people per square mile) of the continent: 370 people per square mile or 37 people per square mile? Explain.

4. Use the spinner below to find the probabilities listed.

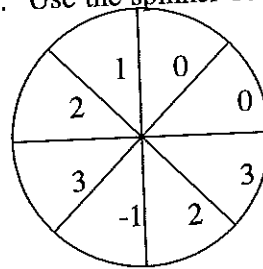

- $P(2) =$
- $P(1) =$
- $P(\text{a negative number}) =$
- $P(4) =$

5. The formula for converting a temperature on the Fahrenheit (F) scale to a temperature on the Celsius (C) scale is: $C = \frac{5}{9}(F - 32)$. Find the Celsius temperature when the Fahrenheit temperature is 86 degrees.

6. A box was cut and folded to make the figure below. Find:

- a.) its volume.

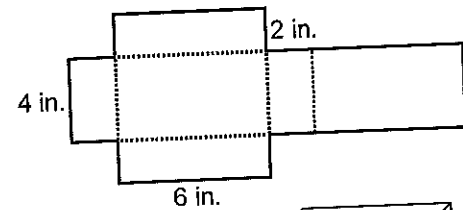

- b.) its surface area.



7. A triangle with vertices $X(-1, 2)$, $Y(2, 3)$, $Z(3, -1)$ is translated by 2 units horizontally and -3 units vertically. Write the coordinates of the new triangle, $X' Y' Z'$.

8. If you could fold a piece of paper in half 10 times, how many pieces of paper thick would it be?

| # of folds | 0 | 1 | 2 | 3 | 4 | ... | 10 |
|-------------------|---|---|---|---|----|-----|-------|
| # of sheets thick | 1 | 2 | 4 | 8 | 16 | ... | _____ |

9. Find the value of c . Indicate whether c is a rational or irrational number.

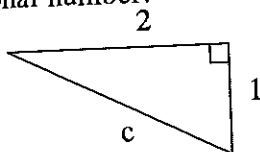

10. If $a = 25$, find the value of b .

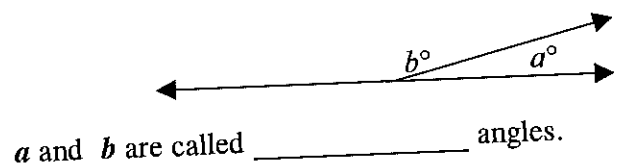

a and b are called _____ angles.

1. If $y = 36$, $x = 25$, $w = 20$, evaluate the expression:

$$\frac{5w}{x} - (y+w)$$

2. Simplify

$$\frac{1}{4}(2x+12) = \frac{1}{2}x$$

3. Use the graph to answer the following questions.

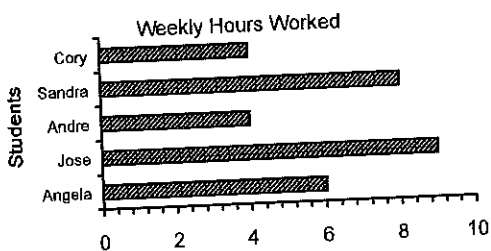

- What is the mean number of hours worked by these students each week? _____
- What is the median number of hours? _____
- What is the mode of this data? _____
- What is the range of hours worked weekly? _____

5. A mosquito lands on one of the squares in the diagram shown. What is the probability that it lands on a square containing:

- an even number? _____
- a multiple of 3? _____
- a multiple of 5? _____
- a multiple of both 3 and 5? _____

| | | | |
|----|----|----|----|
| 1 | 2 | 3 | 4 |
| 5 | 6 | 7 | 8 |
| 9 | 10 | 11 | 12 |
| 13 | 14 | 15 | 16 |

4. Identify the x-intercept and the y-intercept on the graph.

Complete the table

| x | y |
|----|---|
| -2 | |
| -1 | |
| 0 | |
| 1 | |
| 2 | |

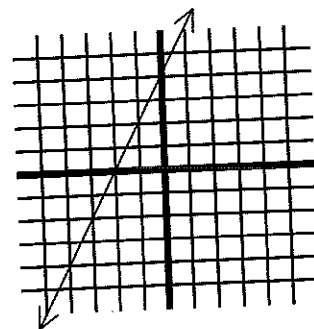

6. At a certain time of day, a flagpole casts a shadow 8.75 feet long. At the same time of day, a 6-foot-tall person casts a shadow that is 1.75 feet long. How tall is the flagpole? Draw a diagram of the two objects and their shadows. Write a proportion to solve for the height of the flagpole.

7. Define the function for this table.

| x | f(x) |
|---|------|
| 1 | -5 |
| 2 | -4 |
| 3 | -3 |

$$f(x) = \underline{\hspace{2cm}}$$

8. What percent of the figure below is shaded?

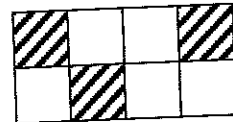

9. Solve for x: $\frac{5.6}{x} = \frac{8.96}{3.2}$

10. Find the value of b and indicate whether it is a rational or irrational number.

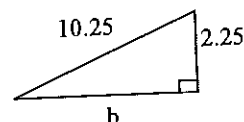

1. Evaluate: $5 - 3^2 + 18 \div 2$

2. Bill works at a local restaurant, earning \$300 per week. Today he was told that he will be given a raise of 10% starting next week. What will his new weekly salary be?

3. The Maple Car Rental Company charges a flat fee of \$45, plus \$1.00 per mile to rent a car. Use this information to calculate the cost in the table.

| miles traveled | cost |
|----------------|------|
| 25 | |
| 50 | |
| 75 | |
| 100 | |

4. Fill in the blanks below.

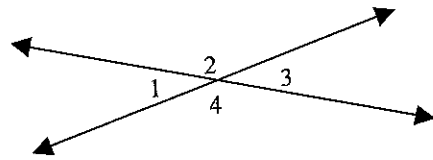

- a) $\angle 1$ and $\angle \underline{\quad}$ are a pair of vertical angles.
 b) $\angle 1$ and $\angle \underline{\quad}$ are a pair of supplementary angles.

5.

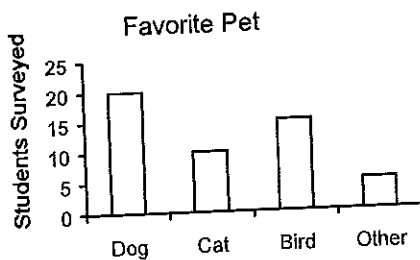

- a) How many students claim a cat as the favorite pet?
 b) How many students were surveyed?
 c) What percent of those surveyed chose a bird as their favorite pet?

6. Graph trapezoid BIRD with vertices B(1, 1), I(2,4), R(6, 4), D(7, 1). Draw its reflection across the x axis. Label its new coordinates.

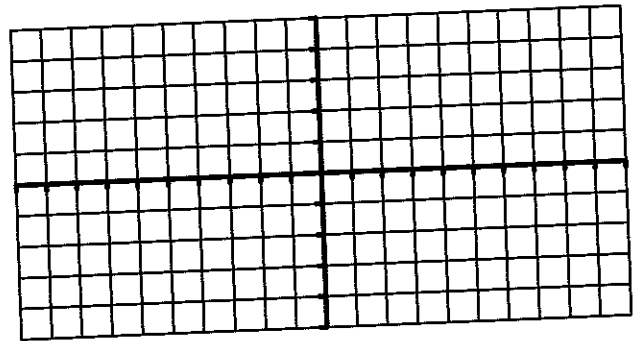

7. Solve the equation. Show each step and check the solution: $\frac{x}{5} - 6 = -2$

8. Solve the equation. Show each step and check your solution: $7n - 11 = 73$

9. Order the numbers from least to greatest:

$\sqrt{91}, 9, \frac{79}{9}, 9.0002$

10. Evaluate: $6^2 + (4 \cdot 3)^2 - 4^3$

1. Evaluate:

a) $3\frac{1}{2} + 4\frac{2}{3}$

b) $3\frac{1}{2} \div 4\frac{2}{3}$

2. Check all that apply:

| | Real Number | Rational Number | Integer | Whole Number | Natural (Counting) |
|-------------|-------------|-----------------|---------|--------------|--------------------|
| -6 | | | | | |
| $2.\bar{3}$ | | | | | |
| $1/2$ | | | | | |
| 19 | | | | | |
| $\sqrt{2}$ | | | | | |
| 0 | | | | | |

3. Evaluate $2x + 3y^2$ if $x = -4$ and $y = 5$.

4. Cindy multiplied her age by 5, subtracted 12, and then divided by 3. The result was 16. How old is Cindy?

5. Complete the table and graph the linear function.
 $y = 2x - 1$

| x | y |
|----|---|
| -2 | |
| -1 | |
| 0 | |
| 1 | |
| 2 | |

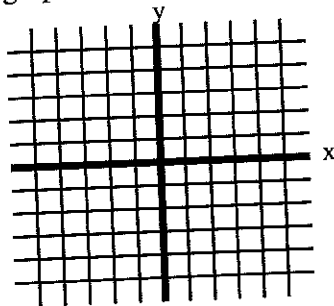

6. A jar contains 15 colored balls. 3 of the balls are red, 4 are white, 5 are blue, and 3 are orange. If you reach into the jar randomly and remove one ball, what is the probability that its color will be: (Round to the nearest percent.)

- a) white? _____ b) either orange or red? _____
c) green? _____ d) anything but blue? _____

7. Name the property illustrated by each equation:

a) $3(1000 - 1) = 3000 - 3$ _____

b) $(4 \cdot 3) \cdot 7 = 4 \cdot (3 \cdot 7)$ _____

c) $8 + 20 = 20 + 8$ _____

d) $x + 0 = x$ _____

9. You are on the 8th grade dance committee and in charge of purchasing the refreshments. Chips cost 79¢ a bag and sodas cost 99¢ a bottle. If you are asked to buy 12 bags of chips and 25 sodas, and you are given \$35, calculate whether or not that will be enough money. (Do not include sales tax.)

8. If it takes 8 hours to drive 435 miles, how many hours would you expect it would take to drive 650 miles if you travel at the same rate? (Round to hundredths.)

10. solve

$$-18 - \frac{3}{4}x = 3$$

1. Rewrite the expression using an exponent.

a.) $2 \cdot 2 \cdot 2 \cdot 2 \cdot 2 \cdot 2 \cdot 2 =$ _____

b.) $w \cdot w \cdot w \cdot w =$ _____

c.) $n^2 \cdot n^3 =$ _____

2. Nike stock began the day on Monday at a price of $132\frac{7}{8}$, and increased $2\frac{3}{8}$ during the day. What is the new price for the stock?

3. In 1990, Americans recycled a record 63.6% of the aluminum cans produced. If 55 billion cans were recycled, about how many were produced? Use a proportion to solve.

4. Use the Pythagorean Theorem to find the value of x . Then indicate whether x is rational or irrational.

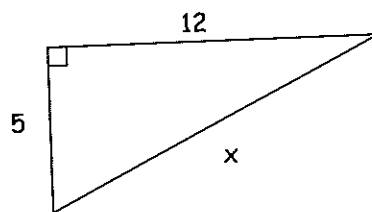

5. Simplify $-18x(3-4.6)-10x$

6. Find the product: $(4.5)(-3)(1000)(5.17)(0)(-7)$

7. Which rectangle has the greater area? By how many units?

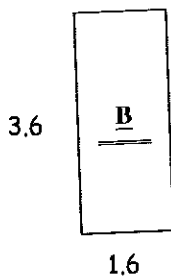
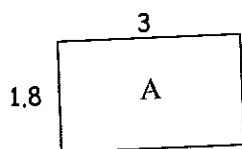

8. For the given circle:

a) find the area using $A = \pi r^2$. (Use $\pi \approx 3.14$ and round to tenths.)

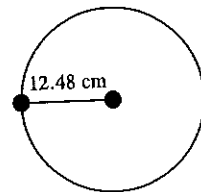

b) find the circumference using $C = \pi d$.

9. Use the data in the stem-and-leaf plot to find the:

| | | |
|---|-------------------|------------|
| 0 | | 8 4 = 84 |
| 1 | 5 | |
| 2 | 2 | |
| 3 | 3 | |
| 4 | 3 5 | |
| 5 | 1 7 8 | |
| 6 | 2 3 5 8 8 8 8 8 9 | |
| 7 | 0 0 4 7 9 | |
| 8 | 2 4 4 8 | |
| 9 | 3 4 5 8 8 | |

a) mean. _____

b) median. _____

c) mode. _____

10. Solve: $-3x + 7 < -29$

1. 64 people play in a singles tennis tournament. In the first round the players pair off to play each other. The winner of the pair advances to the next round. The loser is eliminated. Complete the chart to see how many rounds it will take to declare the one final champion of the tournament.

| | | | | | | | | | |
|-------------------|----|----|--|--|--|--|--|--|--|
| round # | 1 | 2 | | | | | | | |
| number of players | 64 | 32 | | | | | | | |
| number of winners | 32 | | | | | | | | |

3. Find the volume of a rectangular prism that is 5 cm long, 3 cm wide, and 2 cm tall.

2. Draw a reflection of the figure across the dotted line.

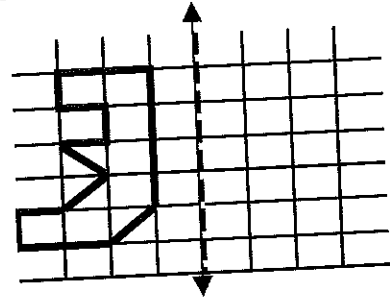

4. Find the value of n.

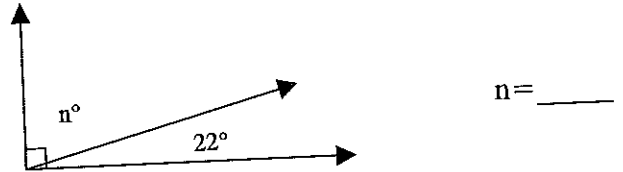

These angles are called _____ angles.

5. Evaluate the expression below. Then create another problem using at least four numbers that result in the same answer.

$$[9 - (8 - 6)^2] - 1$$

6. The circle graph shows the results of a middle school survey. Find the number of students who preferred each category if 300 students responded.

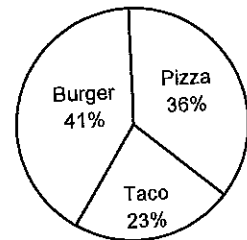

7. What pattern(s) do you notice in the table showing the average family size in the United States?

| | | | | | | |
|-------------|------|------|------|------|------|------|
| Year | 1975 | 1980 | 1985 | 1990 | 1995 | 2000 |
| Family Size | 3.6 | 3.5 | 3.4 | 3.3 | 3.2 | 3.1 |

If the average family size keeps changing at the same rate, what would the family size be in the year 2010?

8. Between which two consecutive whole numbers does $\sqrt{42}$ lie?

9. Graph the information from the table on the coordinate system:

| | |
|----------------|------------------------|
| Time (seconds) | Speed (miles per hour) |
| 0 | 0 |
| 5 | 20 |
| 10 | 45 |
| 15 | 55 |
| 20 | 60 |

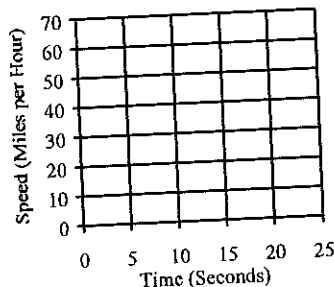

10. Complete each pattern:

a) $-3, -11, -19, -27, \underline{\hspace{1cm}}, \underline{\hspace{1cm}}, \underline{\hspace{1cm}}$

b) $4, -8, 12, -16, \underline{\hspace{1cm}}, \underline{\hspace{1cm}}, \underline{\hspace{1cm}}$

c) $3, 9, 27, 81, \underline{\hspace{1cm}}, \underline{\hspace{1cm}}, \underline{\hspace{1cm}}$

d) $1, 3, 7, 15, 31, \underline{\hspace{1cm}}, \underline{\hspace{1cm}}, \underline{\hspace{1cm}}$

Summer Math Packet

Part 2

REVIEW: Surface Areas of Cylinders

Name _____

Key Concept and Vocabulary

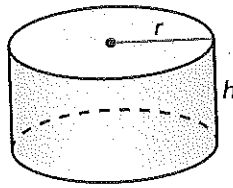

$$S = 2\pi r^2 + 2\pi rh$$



Visual Model

Net for a Circular Cylinder

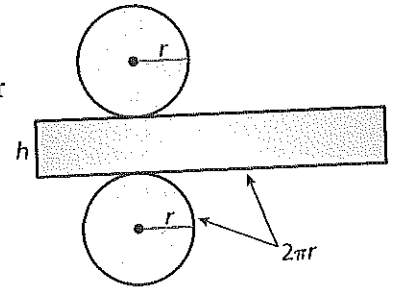

Skill Example

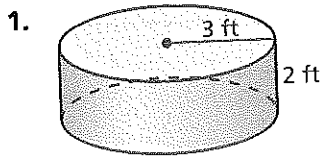

$$\begin{aligned} S &= 2\pi \cdot 3^2 + 2\pi \cdot 3 \cdot 2 \\ &= 18\pi + 12\pi \\ &= 30\pi \text{ ft}^2 \end{aligned}$$

Application Example

2. Find the surface area of the soup can.

$$\begin{aligned} S &= 2\pi \cdot 1.5^2 + 2\pi \cdot 1.5 \cdot 5 \\ &= 4.5\pi + 15\pi \\ &= 19.5\pi \text{ in.}^2 \end{aligned}$$

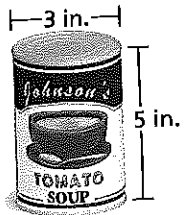

∴ The area is 19.5π square inches.

PRACTICE MAKES PURR-FECT™



Check your answers at BigIdeasMath.com.

Find the surface area of the circular cylinder.

3. Circular Cylinder

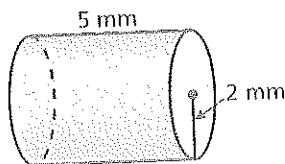

$$S = \underline{\hspace{2cm}}$$

4. Circular Cylinder

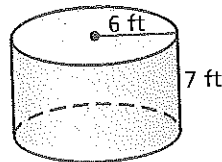

$$S = \underline{\hspace{2cm}}$$

5. Circular Cylinder

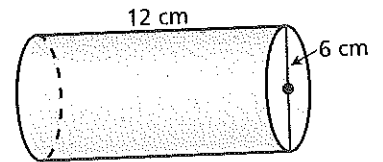

$$S = \underline{\hspace{2cm}}$$

6. Circular Cylinder

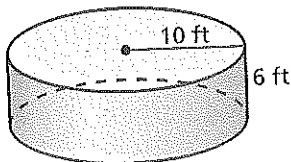

$$S = \underline{\hspace{2cm}}$$

7. Circular Cylinder

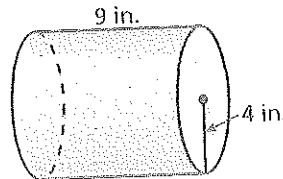

$$S = \underline{\hspace{2cm}}$$

8. Circular Cylinder

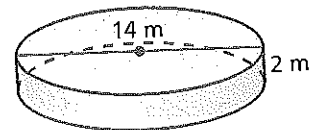

$$S = \underline{\hspace{2cm}}$$

9. **OIL TANKER TRUCK** The truck's tank is a stainless steel cylinder. How many square feet of stainless steel are needed to make the tank? _____

10. **OIL TANKER TRUCK** What percent of the stainless steel in the tank is used to make the two ends? _____

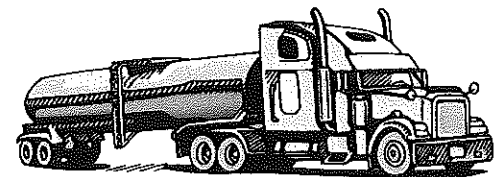

Length = 50 ft
Radius = 4 ft

REVIEW: Surface Areas of Pyramids and Cones

Name _____

Key Concept and Vocabulary

$S = \text{Base Area} + \text{Lateral Area}$

Visual Model

Net for a Square Pyramid

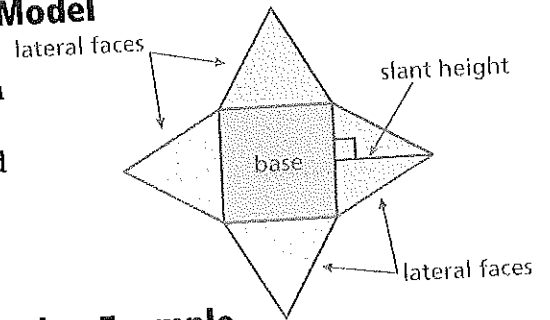

Skill Example

1. Cone

$$S = \pi r^2 + \pi r \ell$$

$$= \pi \cdot 2^2 + \pi \cdot 2 \cdot 4$$

$$= 12\pi \text{ in.}^2$$

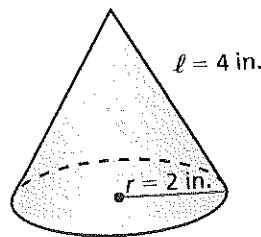

Application Example

2. Find the lateral surface area of the square pyramid.

$$S = 4 \left(\frac{1}{2} \cdot 40 \cdot 35 \right)$$

$$= 2800 \text{ m}^2$$

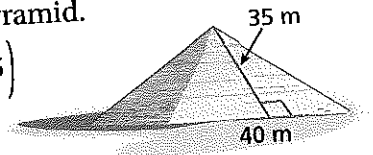

The area is 2800 square meters.

PRACTICE MAKES PURR-FECT™

Check your answers at BigIdeasMath.com.

Find the surface area of the pyramid or cone.

3. Square Pyramid

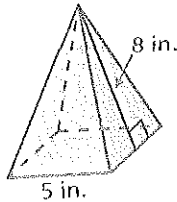

$S = \underline{\hspace{2cm}}$

4. Square Pyramid

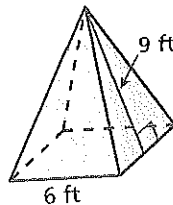

$S = \underline{\hspace{2cm}}$

5. Square Pyramid

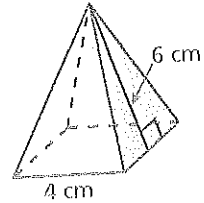

$S = \underline{\hspace{2cm}}$

6. Cone

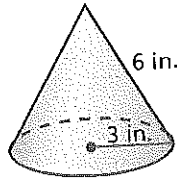

$S = \underline{\hspace{2cm}}$

7. Cone



$S = \underline{\hspace{2cm}}$

8. Cone

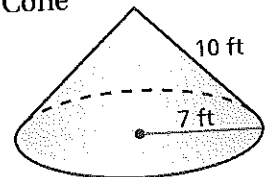

$S = \underline{\hspace{2cm}}$

9. **VOLCANO** Find the lateral surface area of the volcano. Use 3.14 for π . Round your answer to the nearest hundred square feet. _____

10. **VOLCANO** Find the area of the circular region covered by the base of the volcano. Use 3.14 for π . Round your answer to the nearest hundred square feet. _____

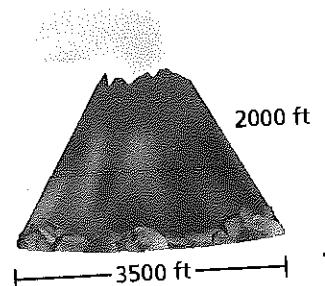

REVIEW: Surface Areas of Prisms

Name _____

Key Concept and Vocabulary

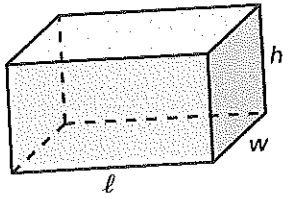

$$S = 2lw + 2lh + 2wh$$



Visual Model

Net for a Rectangular Prism

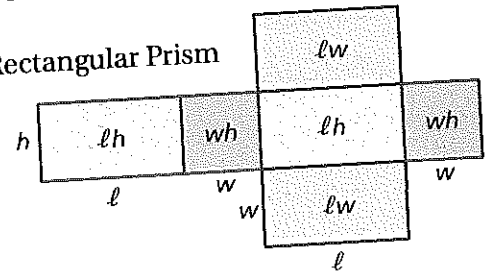

Application Example

2. Find the surface area of the block.

$$\begin{aligned} S &= 2\left(\frac{1}{2} \cdot 3 \cdot 4\right) + 4 \cdot 5 + 3 \cdot 4 + 4 \cdot 4 \\ &= 12 + 20 + 12 + 16 \\ &= 60 \text{ cm}^2 \end{aligned}$$

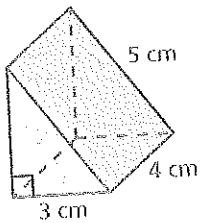

The area is 60 cm^2 .

Skill Example

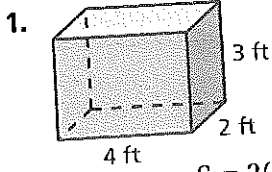

$$\begin{aligned} S &= 2(4 \cdot 2) + 2(4 \cdot 3) + 2(2 \cdot 3) \\ &= 16 + 24 + 12 \\ &= 52 \text{ ft}^2 \end{aligned}$$



PRACTICE MAKES PURR-FECT™

Check your answers at BigIdeasMath.com.

Find the surface area of the prism.

3. Rectangular Prism

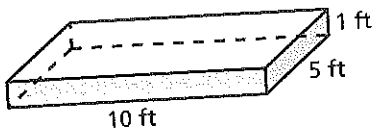

$S = \underline{\hspace{2cm}}$

4. Rectangular Prism

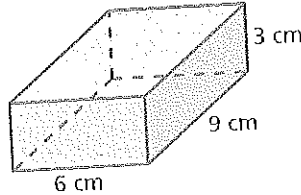

$S = \underline{\hspace{2cm}}$

5. Rectangular Prism

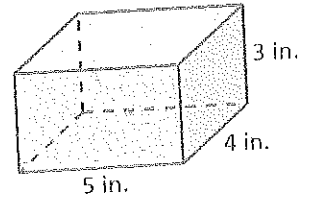

$S = \underline{\hspace{2cm}}$

6. Triangular Prism

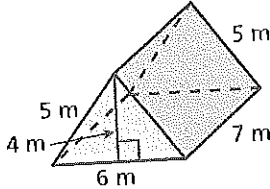

$S = \underline{\hspace{2cm}}$

7. Triangular Prism

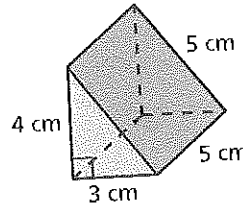

$S = \underline{\hspace{2cm}}$

8. Triangular Prism

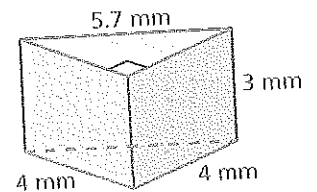

$S = \underline{\hspace{2cm}}$

9. **AQUARIUM** How much glass is used to make the four sides of the aquarium? _____

10. **AQUARIUM** How much glass is used to make the base of the aquarium? _____

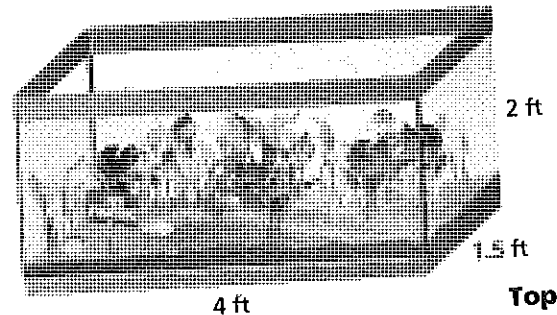

REVIEW: Volumes of Pyramids

Name _____

Key Concept and Vocabulary

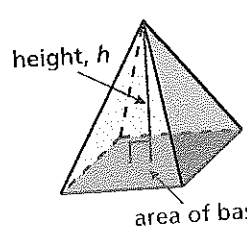

$$V = \frac{1}{3} Bh$$



Visual Model

The volume of a pyramid is *one-third* the volume of the prism that has the same base and height.

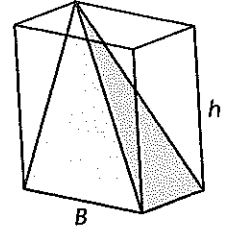

Skill Example

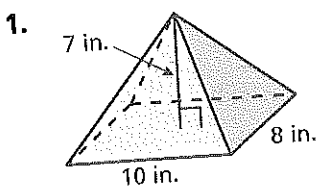

$$\begin{aligned} V &= \frac{1}{3} Bh \\ &= \frac{1}{3} \cdot (8 \cdot 10) \cdot 7 \\ &= \frac{560}{3} \\ &= 186\frac{2}{3} \text{ in.}^3 \end{aligned}$$

Application Example

2. Find the volume of the square pyramid.

$$\begin{aligned} V &= \frac{1}{3} \cdot (40^2) \cdot 30 \\ &= 16,000 \text{ m}^3 \end{aligned}$$

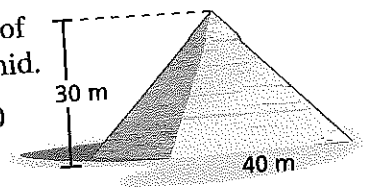

∴ The volume is 16,000 cubic meters.

PRACTICE MAKES PURR-FECT™



Check your answers at BigIdeasMath.com.

Find the volume of the pyramid.

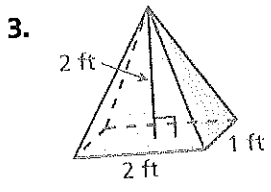

$V = \underline{\hspace{2cm}}$

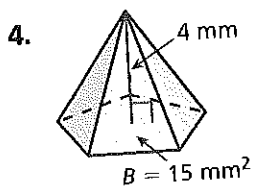

$V = \underline{\hspace{2cm}}$

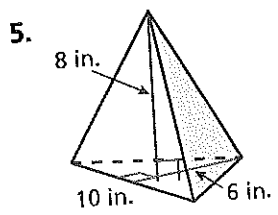

$V = \underline{\hspace{2cm}}$

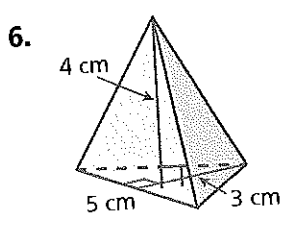

$V = \underline{\hspace{2cm}}$

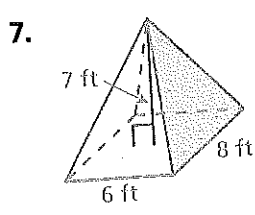

$V = \underline{\hspace{2cm}}$

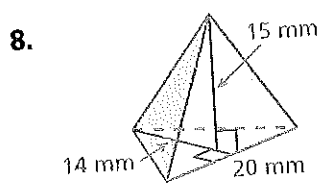

$V = \underline{\hspace{2cm}}$

9. **PYRAMID** The pyramid has a volume of 2000 cubic feet. Find a set of possible dimensions for the pyramid.

$w = \underline{\hspace{1cm}}, \ell = \underline{\hspace{1cm}}, h = \underline{\hspace{1cm}}$

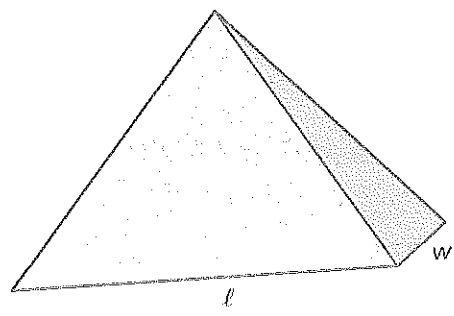

REVIEW: Volumes of Cylinders

Name _____

Key Concept and Vocabulary

Base

$$V = Bh$$

$$= \pi r^2 h$$

Volume

Visual Model

If each coin has a volume of πr^2 , then h coins have a volume of

$$V = \pi r^2 h.$$



Skill Example

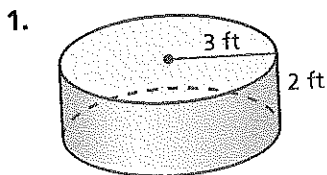

$$V = \pi \cdot 3^2 \cdot 2$$

$$= 18\pi \text{ ft}^3$$

Application Example

2. How much soup is in the can?

$$V = \pi \cdot 1.5^2 \cdot 5$$

$$= 11.25\pi \text{ in.}^3$$

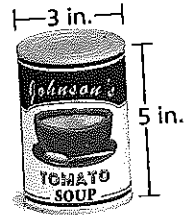

There are 11.25π cubic inches of soup.

PRACTICE MAKES PURR-FECT™



Check your answers at BigIdeasMath.com.

Find the volume of the circular cylinder.

3. Circular Cylinder

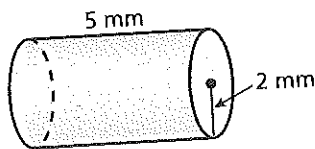

$$V = \underline{\hspace{2cm}}$$

4. Circular Cylinder

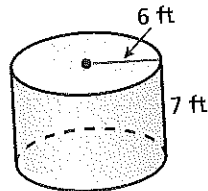

$$V = \underline{\hspace{2cm}}$$

5. Circular Cylinder

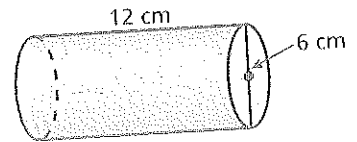

$$V = \underline{\hspace{2cm}}$$

6. Circular Cylinder

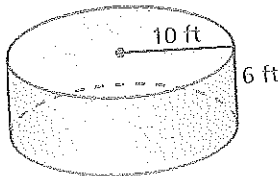

$$V = \underline{\hspace{2cm}}$$

7. Circular Cylinder

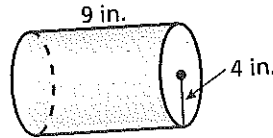

$$V = \underline{\hspace{2cm}}$$

8. Circular Cylinder

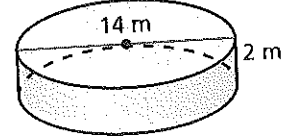

$$V = \underline{\hspace{2cm}}$$

9. **OIL TANKER TRUCK** The truck's tank is a stainless steel cylinder. How much oil does the tank hold? _____

10. **OIL TANKER TRUCK** There are about 7.5 gallons in 1 cubic foot. How many gallons of oil can the tank hold? _____

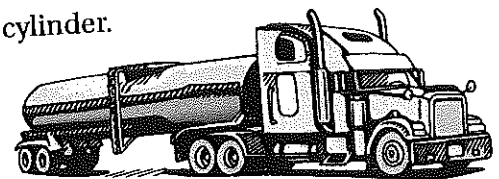

Length = 50 ft
Radius = 4 ft

REVIEW: Volumes of Prisms

Name _____

Key Concept and Vocabulary

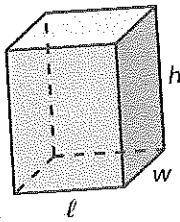

Base
 $V = Bh$
 $= lwh$



Visual Model

Volume of a Rectangular Prism

$$V = 2 \cdot 4 \cdot 3 = 24 \text{ units}^3$$

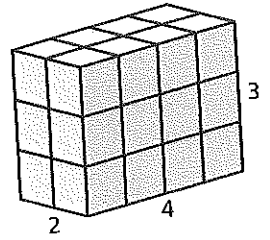

Skill Example

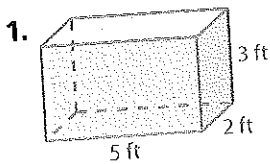

$$V = 5 \cdot 2 \cdot 3 = 30 \text{ ft}^3$$

Application Example

2. Find the volume of the block.

$$V = Bh = \left(\frac{1}{2} \cdot 3 \cdot 4\right) \cdot 5 = 30 \text{ cm}^3$$

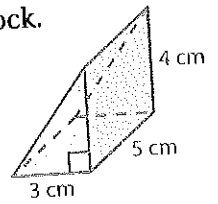

∴ The volume is 30 cubic centimeters.

PRACTICE MAKES PURR-FECT™



Check your answers at BigIdeasMath.com.

Find the volume of the prism.

3. Rectangular Prism

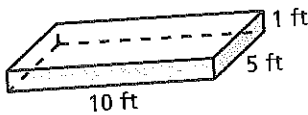

$V =$ _____

4. Rectangular Prism

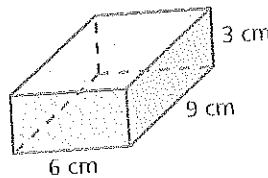

$V =$ _____

5. Rectangular Prism

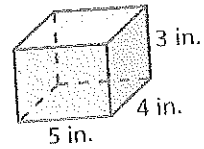

$V =$ _____

6. Triangular Prism

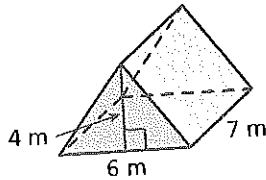

$V =$ _____

7. Triangular Prism

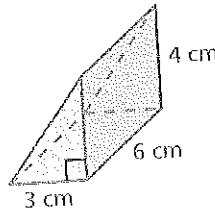

$V =$ _____

8. Triangular Prism

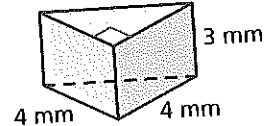

$V =$ _____

9. **AQUARIUM** How much water is needed to fill the aquarium? _____

10. **AQUARIUM** There are about 7.5 gallons in 1 cubic foot. How many gallons of water does the aquarium hold? _____

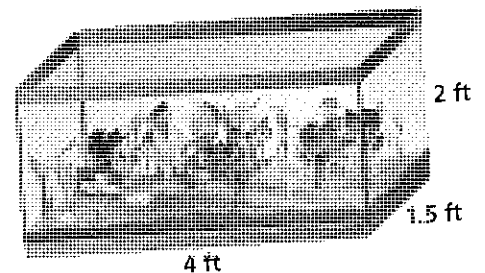

Algebra I Prep Packet

Calculating Percents

Percent of a number, percent change, percent increase/decrease.

| | | | |
|--|--|--|--|
| 1) What is 40% of 82? | 2) What is 110% of 95? | 3) What is 15.5% of 20? | 4) What is 75% of 150? |
| 5) Write two expressions that could be used to find 80% of x . | | 6) Write two expressions that could be used to find 105% of x . | |
| 7) A price increases from \$82 to \$89.38. What is the percent change? | 8) A price decreases from \$254 to \$213.36. What is the percent change? | 9) The number of students increases from 640 to 768. What is the percent change? | 10) A population decreases from 14,500 to 12,035. What is the percent change? |
| 11) A dinner bill is \$45 and an 18% tip is left. How much is the tip? | 12) A dinner bill is \$82 and a 15% tip is left. How much is the total cost? | 13) There is a 7% sales tax on a \$425 television. How much is the tax? | 14) There is a 22% room tax on a \$199 hotel rate. What is the total cost of a room for one night? |
| 15) Ken makes \$400 a week before a 5% raise, and then another 6% raise. What is his weekly pay now? | | 16) Amy bought a \$750 couch. She used a 15% off coupon. There is 6% tax on the discounted price. How much does she pay? | |

Calculating Percents

Percent of a number, percent change, percent increase/decrease.

| | | | |
|---|--|---|--|
| 1) What is 60% of 130? | 2) What is 150% of 20? | 3) What is 5.5% of 140? | 4) What is 55% of 180? |
| 5) Write two expressions that could be used to find 22% of x . | | 6) Write two expressions that could be used to find 130% of x . | |
| 7) A price increases from \$50 to \$120. What is the percent change? | 8) A price decreases from \$575 to \$488.75. What is the percent change? | 9) The number of students increases from 890 to 1,000. What is the percent change? | 10) A population decreases from 30,000 to 28,400. What is the percent change? |
| 11) A dinner bill is \$105 and an 18% tip is left. How much is the tip? | 12) A dinner bill is \$65 and a 15% tip is left. How much is the total cost? | 13) There is a 6% sales tax on a \$878 television. How much is the tax? | 14) There is a 21.5% room tax on a \$299 hotel rate. What is the total cost of a room for one night? |
| 15) Kyle makes \$600 a week before a 6% raise, and then a 4% pay cut. What is his weekly pay now? | | 16) Andrew bought a \$1,050 couch. He used a 20% off coupon. There is 7% tax on the discounted price. How much does he pay? | |

Using Formulas

Solve using the given formulas. Round to the nearest hundredth.

Use the formula $d = rt$ for questions 1-4.

1) Alex travels 46 miles per hour for 3.2 hours. How far has he gone?

2) Ben just drove 426 miles in 6.4 hours. What was his average rate of speed?

3) Mia is driving at a constant speed of 55 mph and drives 236.5 miles. How long was she driving?

4) Eric drives 62 mph for $5\frac{1}{4}$ hours. How far does he drive?

Use the formulas $\frac{5}{9}(F-32)=C$ and $\frac{9}{5}C+32=F$ for questions 5-8.

5) Convert 80°F to Celsius.

6) Convert 42.5°F to Celsius.

7) Convert 12°C to Fahrenheit.

8) Convert 27.75°C to Fahrenheit.

Use the formula $I = Prt$ for questions 9-12.

9) You put \$5,000 in the bank for 4 years with a 1.2% interest rate. How much interest is earned?

10) James earned \$3,000 interest on an investment that he put in the bank for 6 years with a 5% interest rate. How much was his initial deposit?

11) Kyle puts \$740 in the bank for 5.5 years with a $2\frac{1}{2}\%$ interest rate. How much money does he have in the bank all together after 5.5 years?

Using Formulas

Solve using the given formulas. Round to the nearest hundredth.

Use the formula $d = rt$ for questions 1-4.

1) Jake travels 60 miles per hour for 5.5 hours. How far has he gone?

2) Brad just drove 325 miles in 4.5 hours. What was his average rate of speed?

3) Monica is driving at a constant speed of 63 mph and drives 487.2 miles. How long was she driving?

4) Evan drives 55 mph for $4\frac{1}{2}$ hours. How far does he drive?

Use the formulas $\frac{5}{9}(F-32)=C$ and $\frac{9}{5}C+32=F$ for questions 5-8.

5) Convert 102°F to Celsius.

6) Convert 68.5°F to Celsius.

7) Convert 5.8°C to Fahrenheit.

8) Convert 32°C to Fahrenheit.

Use the formula $I = Prt$ for questions 9-12.

9) You put \$8,500 in the bank for 2 years with a 0.75% interest rate. How much interest is earned?

10) Jon earned \$480 interest on an investment that he put in the bank for 4 years with a 2% interest rate. How much was his initial deposit?

11) Kim puts \$875 in the bank for 3 years with a $3\frac{1}{2}\%$ interest rate. How much money does she have in the bank all together after 3 years?

Scale and Proportions

Round to the nearest tenth.

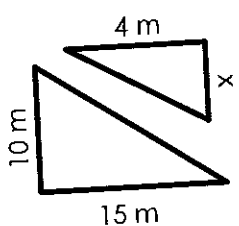
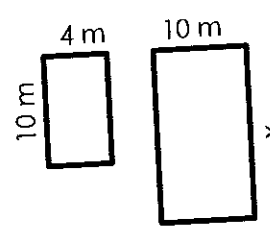
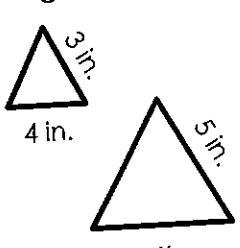
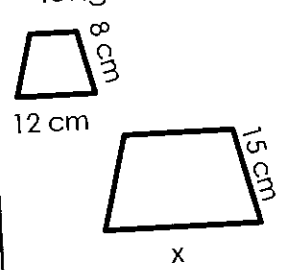
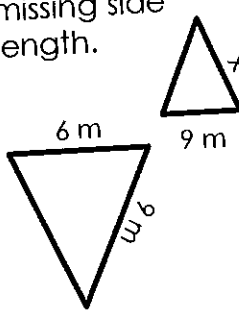
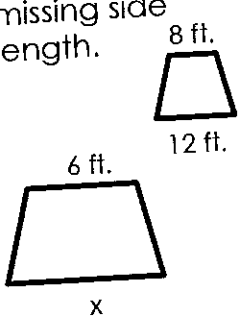
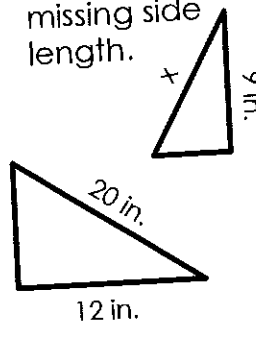
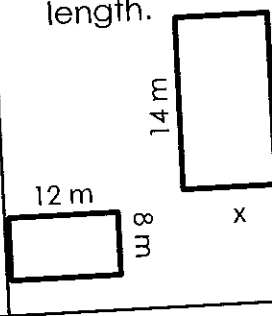
| | | | |
|--|---|--|---|
| <p>1) Find the missing value.</p> $\frac{3}{5} = \frac{15}{x}$ | <p>2) Find the missing value.</p> $\frac{x}{6} = \frac{15}{20}$ | <p>3) Find the missing value.</p> $\frac{2}{8} = \frac{x}{7}$ | <p>4) Find the missing value.</p> $\frac{12}{x} = \frac{5}{1}$ |
| <p>5) Determine the missing side length.</p>  | <p>6) Determine the missing side length.</p>  | <p>7) Determine the missing side length.</p>  | <p>8) Determine the missing side length.</p>  |
| <p>9) Determine the missing side length.</p>  | <p>10) Determine the missing side length.</p>  | <p>11) Determine the missing side length.</p>  | <p>12) Determine the missing side length.</p>  |
| <p>13) Find the missing value.</p> $\frac{3.5}{6} = \frac{10}{x}$ | <p>14) Find the missing value.</p> $\frac{x}{2} = \frac{13}{15}$ | <p>15) Find the missing value.</p> $\frac{1}{6} = \frac{x}{15}$ | <p>16) Find the missing value.</p> $\frac{5}{x} = \frac{2}{1}$ |

Scale and Proportions

Round to the nearest tenth.

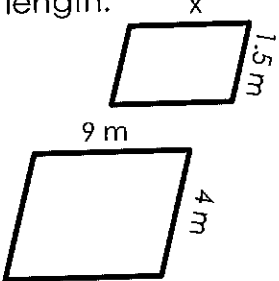
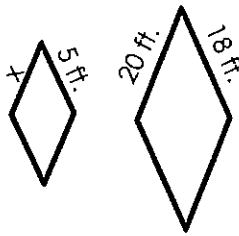
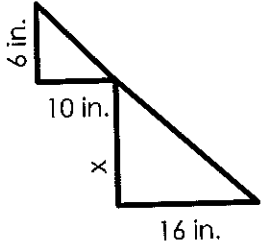
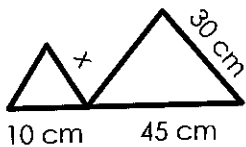
| | | | |
|---|--|--|---|
| <p>1) A model car has been made using a scale factor of 1.5 inches : 3 feet. If the actual car is 13.75 feet long, what is the length of the model?</p> | <p>2) A model airplane has been made using a scale factor of 4 inches : 6.5 feet. If the model plane is 30 inches long, how long is the actual airplane?</p> | | |
| <p>3) Determine the missing side length.</p>  | <p>4) Determine the missing side length.</p>  | <p>5) Determine the missing side length.</p>  | <p>6) Determine the missing side length.</p>  |
| <p>7) Find the missing value.</p> $\frac{5}{6} = \frac{12}{x}$ | <p>8) Find the missing value.</p> $\frac{x}{9} = \frac{10}{25}$ | <p>9) Find the missing value.</p> $\frac{1}{2} = \frac{x}{13}$ | <p>10) Find the missing value.</p> $\frac{4.5}{x} = \frac{15}{6}$ |
| <p>11) A scale on a map is 1 in : 30 miles. How far will you travel if the distance on a map is 8.75 inches?</p> | | <p>12) The ratio of boys to girls in your class is 2 : 3. If there are 15 girls in your class, how many boys are there?</p> | |

Order of Operations

Simplify each expression. Round to the nearest hundredth.

| | | |
|---|---|--|
| 1) $4^2 + 2(6) - 8$ | 2) $9 \div 3 + 6 \cdot 2 \div 2^2$ | 3) $20 - 4(4) - 2 + 6$ |
| 4) $9 - 6 + 2(3^2 + 4)$ | 5) $-10 + 4(3 - 8) + 2^2$ | 6) $5^2 + 6(2 \cdot 6 \div 3) - 4^2$ |
| 7) $12 - 3^2(8 - 4 \cdot 5)$ | 8) $-10 + 3(12 \div 6 \cdot -2)^2$ | 9) $2.2 \cdot 9 + 8 \div 0.4 - 6$ |
| 10) $1.5 + 2.3 - 0.75(4 \cdot 2.6)$ | 11) $5 - \frac{1}{2} (6 \frac{1}{2} + 14 - 12 \frac{2}{3})$ | 12) $10 \frac{3}{4} + 2 \frac{1}{5} \cdot 6 \frac{1}{8} - 3 \frac{4}{5}$ |
| 13) $5^2 - 12(3 \frac{1}{2} \cdot 3.4 - 8)$ | 14) $-5 \frac{1}{2} + \frac{1}{4} ((-4)^2 + 8)$ | 15) $6(3.5 \cdot 2)^2 - 18 \div 2 \frac{1}{2}$ |

Order of Operations

Simplify each expression. Round to the nearest hundredth.

| | | |
|--|--|---|
| 1) $5^2 - 3(4) + 5$ | 2) $12^2 \div 6 + 8 \cdot 3 \div 2$ | 3) $19 - 8 \cdot 2 - 1 + 9$ |
| 4) $5 - 4 + 6(2^2 + 5)$ | 5) $-8 - 5(12 - 15) + 4^2$ | 6) $(-2)^2 + 8(5 \cdot 2 \div 2) + 3^2$ |
| 7) $10 + 8(-4 \cdot 2 - 5)$ | 8) $-4 - 6(3 \cdot 2 + 8)$ | 9) $14.5 \cdot 0.6 + 8 \div 2 + 4.5$ |
| 10) $16.2 + 0.8 + 12(2 + 6.3)$ | 11) $10\frac{1}{2} + 6(13 - 10\frac{1}{4}) + 6\frac{1}{2}$ | 12) $8 \div \frac{4}{5} + \frac{1}{2} (9\frac{1}{2} - 6)$ |
| 13) $2^2 - 6\frac{1}{2}(3^3 + 4 \div 2^2) - 6$ | 14) $-3\frac{1}{5} + \frac{1}{2}(8^2 - 9 \div 3)$ | 15) $4\frac{1}{2}(-9 \cdot 2\frac{1}{2})^2 - 20 + 5\frac{1}{4}$ |

Simplifying Expressions

Simplify each expression.

| | | | |
|---------------------------------------|---|---|---|
| $ -15-4 \cdot 2$ | $ -5+2 -3$ | $ -42-8 $ | $ 3\cdot -2 +6-9$ |
| $\frac{1}{5}-\frac{2}{3}+\frac{4}{5}$ | $\frac{2}{5}\cdot\frac{1}{4}+\frac{1}{2}$ | $5\frac{1}{2}\div\frac{1}{4}-\frac{7}{8}$ | $-\frac{5}{6}+4\frac{1}{3}-\frac{1}{4}$ |
| $3-4(8-6)$ | $\frac{1}{2}(8-10)+6$ | $8-5+2\cdot 6\div 3$ | $-3(5\cdot 4)+12\div 6$ |
| $5(x+2y)-2(x-3y)$ | $-4(x-7)+x$ | $\frac{1}{2}(x-7)+4x-10$ | $8(x+4y)+3(-4x+y)$ |
| $\frac{1}{5}(x+10)+5x$ | $-4.8(2-8.2x)+6x-3$ | $\frac{1}{2}(8y+2x)-\frac{3}{4}x$ | $-18x(3-4.6)-10x$ |

Simplifying Expressions

Simplify each expression.

| | | | |
|-----------------------------------|---------------------------------------|---|---|
| $ -1+8 \cdot 3$ | $ -10+-2 +8$ | $ -2 \cdot -8 $ | $ -9+2 -6+7$ |
| $4-\frac{2}{5}+\frac{1}{2}$ | $\frac{2}{3}+\frac{1}{3}-\frac{1}{4}$ | $2\frac{3}{4} \div \frac{1}{2} - \frac{2}{5}$ | $-\frac{7}{8}+2\frac{1}{2} \cdot \frac{1}{4}$ |
| $5-12(2-6)$ | $\frac{2}{5}(15-10)+4\frac{1}{2}$ | $4-15+2 \cdot 9 \div 3$ | $-\frac{1}{2}(5 \cdot 6)+10 \div 2$ |
| $-4(x-3y)+2(x-4y)$ | $-4+2(x-3)-2x$ | $-\frac{1}{2}(8x-4)+4x-1$ | $(2x-7y)-2(8x-3y)$ |
| $\frac{1}{4}(2x+12)-\frac{1}{2}x$ | $7.8(2-0.2x)+1.5x$ | $\frac{2}{3}(9y-6x)+\frac{1}{4}x$ | $-8x(1.7-2.3)-1.8x$ |

Evaluating Expressions

Evaluate each expression.

| | | | |
|--|-------------------------------------|---|---|
| $3x - 10 + 4$ if $x = 3$ | $\frac{x}{2} + 6x$ if $x = -12$ | $8(x - y)$ if $x = 2, y = 6$ | $x + xy$ if $x = 3, y = -2.5$ |
| $(2x)^2 + 6$ if $x = -2$ | $3x + 4y - 3x$ if $x = 2, y = 4$ | $-10x + \frac{4}{x}$ if $x = -2$ | $3(8x - 10) + 5x$ if $x = \frac{1}{2}$ |
| $x + 8y - (x)^2$ if $x = -5, y = \frac{1}{4}$ | $(8x)^2 + 6x + 2$ if $x = -3$ | $2x^2 + 4y^2 + xy$ if $x = \frac{1}{2}, y = 2$ | $8x + 2y$ if $x = 1.5, y = -2.2$ |
| $\frac{5}{2}(x - 6) + 4$ if $x = 8$ | $3x - 8x^2 + 7$ if $x = 4.5$ | $-2x^2 + 8y$ if $x = 3, y = -9$ | $(-5x)^2 - 3x + x$ if $x = -3.5$ |

Evaluating Expressions

Evaluate each expression.

| | | | |
|--|--|---|--|
| $3x - 12 + 6$ if $x = 2.5$ | $\frac{x}{6} + 2x$ if $x = -18$ | $-2(x - y)$ if $x = 5, y = -8$ | $xy - y$ if $x = 8.5, y = -2$ |
| $(-4x)^2 - 2$ if $x = -4$ | $5x + 7y - 2x$ if $x = 2.5, y = -4$ | $5x + \frac{2}{x}$ if $x = -2$ | $\frac{1}{2}(-4x + 6) + 3x$ if $x = -\frac{1}{4}$ |
| $2x - 4y + x^2$ if $x = 3.5, y = \frac{1}{2}$ | $-5(x)^2 + 2x + 4$ if $x = -5$ | $-x^2 + 2y^2 - xy$ if $x = 2, y = \frac{1}{2}$ | $-3x - 5y$ if $x = 2.5, y = 4.5$ |
| $\frac{3}{4}(x - 6) + 2$ if $x = -14$ | $x + (4x)^2 - 10$ if $x = -2.5$ | $2(x)^2 + 3y$ if $x = -3, y = 4$ | $5x^2 - 3x - x$ if $x = 2\frac{1}{2}$ |

Solving Equations

Solve each equation. Round to the nearest tenth.

| | | | |
|---------------------------------|-------------------------------------|--------------------------------|-------------------------------------|
| $3x + 6 = 20$ | $-\frac{3}{4}x + 6 = 5\frac{5}{16}$ | $7x + 5 = 68$ | $-\frac{7}{8} + 5x = 44\frac{1}{8}$ |
| $-2x - 5 = -23$ | $7x + 6 + x = 62$ | $6 + 3x - 6x = -18$ | $-6.5x + 1 = -29$ |
| $3x - 4(8x - 6) = 20$ | $6x + 7 = -47$ | $-6 - 5x = -41$ | $4x - 9 - 7x = -12$ |
| $3x - 2 - 7x = -22$ | $-54 = 2x + 7x + 9$ | $\frac{1}{2}(x - 8) + 4x = 10$ | $8(x + 4) + 3(-4x) = 32$ |
| $\frac{1}{5}(x + 10) + 5x = 25$ | $-4(2 - 8.2x) = 30$ | $5 + 3x - x = 25$ | $6x + 4 - 7x = 88$ |

Solving Inequalities

Solve each inequality. Round to the nearest tenth. Graph #1 – 6 on the number line.

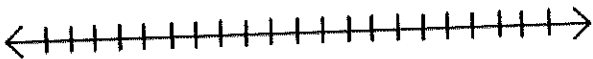
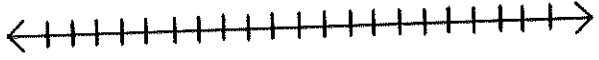
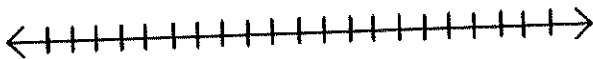
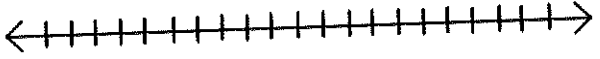
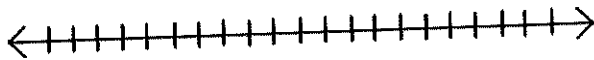
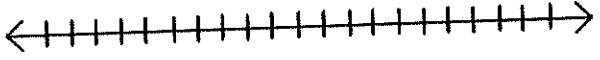
| | | | |
|--|--------------------------------|--|---------------------------|
| $6x - 8 < 20$  | | $4x + 5 \leq -25$  | |
| $\frac{1}{2}x - 4 > -2$  | | $-4 + 3x \leq -12 + 5x$  | |
| $3(-4x + 3) + 2x < 10$  | | $15 - 2x > 21$  | |
| $2x - 2 > -20 + 6x$ | $-2 + 4x > 5x - 5$ | $\frac{1}{4}(16x + 4) + 4x < 10$ | $-2(2x - 4) - 5 \leq -10$ |
| $-2(4x - 2) + 6x \geq -12$ | $\frac{2}{3}(6 + 9x) \geq -10$ | $5 + 3x \leq 12x + 5$ | $-2x + 4 \leq 20$ |

Surface Area & Volume

Round to the nearest hundredth. Use 3.14 for π .

1) Find the surface area.

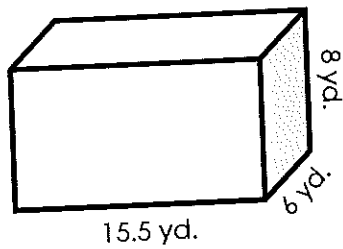

2) Find the volume.

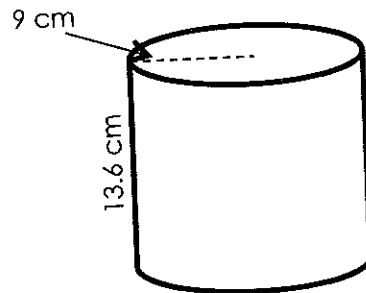

3) Find the volume.

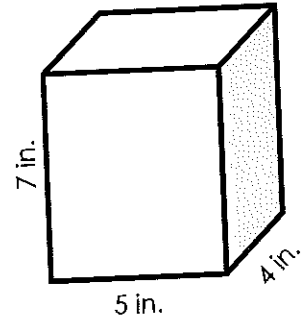

4) Find the surface area.

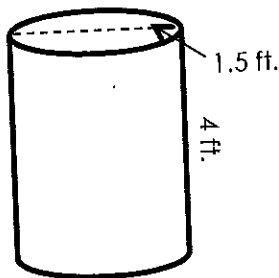

5) Find the volume when filled halfway.

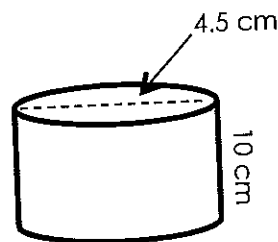

6) Find the volume of the cube when filled 75%.

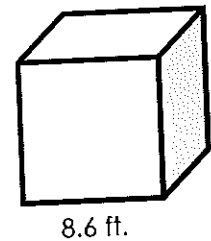

7) Nina is painting a bird house. The bird house is in the shape of a cube and has an edge length of 6.5 inches. How much paint will Nina need?

8) Ryan has a pool in his backyard. The pool measures 52 feet long, 25 feet wide, and 8.5 feet deep. How much water will fit in the pool?

9) How much gift wrap is needed to cover a box measuring 18 inches by 12 inches by 4 inches?

10) A cylindrical lava lamp is 18 inches tall. The radius of the lamp is 5.25 inches. How much liquid is in the lamp?

11) What is the surface area of a box in the shape of a rectangular prism with a length of 8 inches, width of 9 inches, and height of 4 inches?

12) A soda can has a diameter of 2.3 inches and a height of 9.5 inches. What is the volume?

Surface Area & Volume

Round to the nearest hundredth. Use 3.14 for π .

1) Find the surface area.

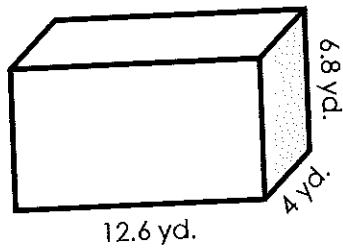

2) Find the volume.

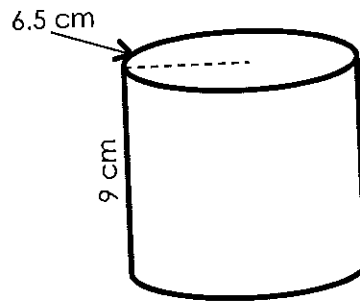

3) Find the volume.

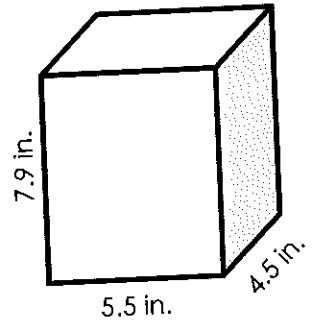

4) Find the surface area.

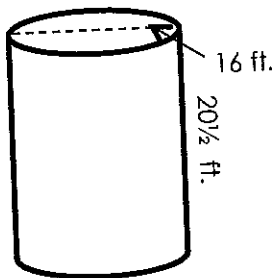

5) Find the volume when filled halfway.

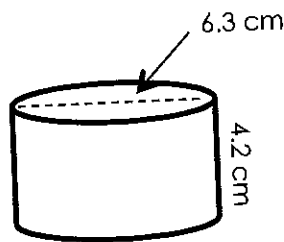

6) Find the volume of the cube when filled 80%.

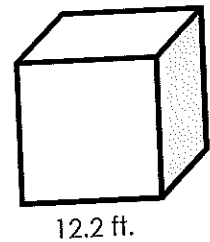

7) Jay is painting a shoe box. The box is in the shape of a cube and has an edge length of 8.75 inches. How much paint will Jay need?

8) The Millers have a pool in his backyard. The pool measures 42 feet long, 23.5 feet wide, and 6 feet deep. How much water will fit in the pool?

9) How much gift wrap is needed to cover a box measuring 16.5 inches by 12.2 inches by 9.5 inches?

10) A cylindrical fish tank is 12 inches tall. The radius of the tank is 4.6 inches. How much water will fill the fish tank?

11) What is the surface area of a box in the shape of a rectangular prism with a length of 6.5 inches, width of 6.5 inches, and height of 4 inches?

12) A shampoo bottle has a diameter of 4.6 inches and a height of 8 inches. What is the volume?

Mixed Review

Round to the nearest hundredth.

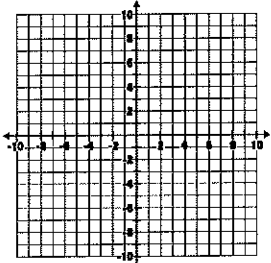
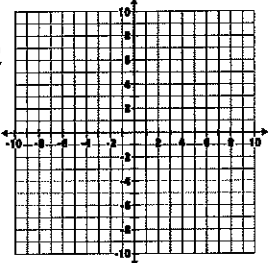
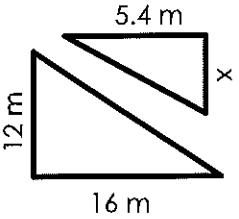
| <p>1) Simplify.</p> $-2(5x+3y)-2(3x-y)$ | <p>2) Solve.</p> $-8+3x-6=-2$ | <p>3) Solve $x+xy$</p> <p>if $x=\frac{1}{2}, y=2.5$</p> | | | | | | | | |
|---|---|--|---|---|---|---|---|---|--------------------------------|--|
| <p>4) Ben drove 584 miles in 8.2 hours. What was his average rate of speed?</p> | <p>5) Graph the equation</p> $y=\frac{3}{5}x-4$  | <p>6) Graph the equation</p> $y=-4x+2$  | | | | | | | | |
| <p>7) How do you find the mean of a set of data?</p> | <p>8) A price decreases from \$986 to \$828.24. What is the percent change?</p> | <p>9) A square flower bed needs mulch, which is sold by the square foot. If the flower bed has a side length of 2.5 feet, how much mulch is needed?</p> | | | | | | | | |
| <p>10) Determine the missing side length.</p>  | <p>11) A dinner bill is \$102 and an 18% tip is left. What is the total spent on dinner?</p> | <p>12) A car rental company charges \$85 plus \$0.22 per mile, m. Write an equation that represents the total cost, c, of renting a car.</p> | | | | | | | | |
| <p>13) Write an equation in slope intercept form for the line represented by the points in the table.</p> <table border="1" data-bbox="448 1854 592 2033"> <thead> <tr> <th>x</th> <th>y</th> </tr> </thead> <tbody> <tr> <td>0</td> <td>6</td> </tr> <tr> <td>2</td> <td>5</td> </tr> <tr> <td>4</td> <td>4</td> </tr> </tbody> </table> | x | y | 0 | 6 | 2 | 5 | 4 | 4 | <p>14) Solve.</p> $-2+4x>5x-6$ | <p>15) A house is 32 feet tall. It casts a shadow that is 45 feet long. What is the distance from the top of the house to the end of the shadow?</p> |
| x | y | | | | | | | | | |
| 0 | 6 | | | | | | | | | |
| 2 | 5 | | | | | | | | | |
| 4 | 4 | | | | | | | | | |